

# Howard B. Mattlin Middle School

---

Incoming Grade 8  
Parent Transition Meeting

January 10, 2017

*Joseph Coladonato, Ed.D., Principal*

*Regina Talento, Assistant Principal (Grades 5 & 7)*

*Andrea Luzzi, Guidance Counselor*

# Meeting Overview

- 8<sup>th</sup> Grade Transition - Student Perspective
- Availability of Core and Special Area Classes
- Options for Acceleration
- Course Recommendations and Self Selection
- Overview of Various Student Programs
- Options for Additional Support During Zero and 9<sup>th</sup> Period

**7<sup>th</sup> to 8<sup>th</sup> Grade Transition**  
**Student Perspective**

---

**Jordan Dohrman**

Howard B. Mattlin Middle School



# Overview of Courses Available

## Core Area Subjects: *(Every Day For One Period)*

- English
- Social Studies
- Science
- Math
- World Languages

## Special Area Subjects:

*(Every Other Day All Year or Every Day for a Semester)*

- Physical Education
- Health
- Technology
- Art

# Acceleration Options

## ➤ Earth Science + Lab

Replaces Science 8 and includes a lab every other day

## ➤ Algebra 1

Replaces Math 8

## ➤ Studio Art

Replaces Art 8

*All accelerated courses are credit bearing and will appear on your child's high school transcript.*

# Accelerated Courses Selection Process

## Common Core Algebra

- Placement determined when students enter grade 7
- Math 7 Accelerated is a prerequisite

## Earth Science

- Currently enrolled in Math 7 Accelerated
- Quarter grades in Math 7 and Science 7

## Studio Art

- Assessment to be administered to evaluate students' art skills



# How will I know the recommendations for my child?

---

## Course Verification Forms

- All parents/guardians will receive printed course verification forms in the mail on or about **March 20, 2017**
- Forms must be signed and returned to the Guidance Office at Mattlin Middle School by **March 31, 2017**
- Parents have the opportunity to discuss the recommendation with the teacher and guidance counselor
- All information will also be available on the Portal

# Course Verification Form

**STUDENT NAME**

**Student Number: XXXXXXXX**

**Grade: 08**

**Requested Courses:**

806 LUNCH 8

812 ENGLISH 8

822 MATH 8

830 SOCIAL STUDIES 8

805 PHYS ED 8

850 SPANISH 1R

903 STUDIO ART

844 HEALTH 8

403-1 EARTH SCI-R+LAB

403-2 EARTH SCI-R-LAB

**Parent/Guardian Signature** \_\_\_\_\_

**Date** \_\_\_\_\_



# What is Self-Selection?

- Opportunity to enroll in an accelerated course when not recommended
  - ✓ Conversation with the student
  - ✓ Conversation with teacher and guidance counselor
- What is the process for self-selection?
  - ✓ Complete and return a Self-Selection form for each accelerated course
  - ✓ Form must be returned by April 7, 2017



Excellence in Education

HOWARD B. MATTLIN MIDDLE SCHOOL  
SELF-SELECTION FORM  
2016-2017



Mattlin PRIDE

\_\_\_\_\_  
Student's First Name

\_\_\_\_\_  
Student's Last Name

\_\_\_\_\_  
Grade in 2015-2016

I would like to self-select my child into the accelerated course circled below. I realize that this was not the recommended course for my child for the upcoming school year. I am also aware that if my child does not perform well in this course and needs a change in placement during the school year, this could significantly impact his/her schedule.

Accelerated Course Offerings – Grade 7

722          Math 7 Accelerated

Accelerated Course Offerings – Grade 8

301          Algebra 1

403-1        Earth Science + Lab

801/903     Studio Art

\_\_\_\_\_  
Parent's Signature

\_\_\_\_\_  
Date

\_\_\_\_\_  
Student's Signature

This form must be returned to the guidance office  
no later than Friday, April 1, 2016.

## Mathematics

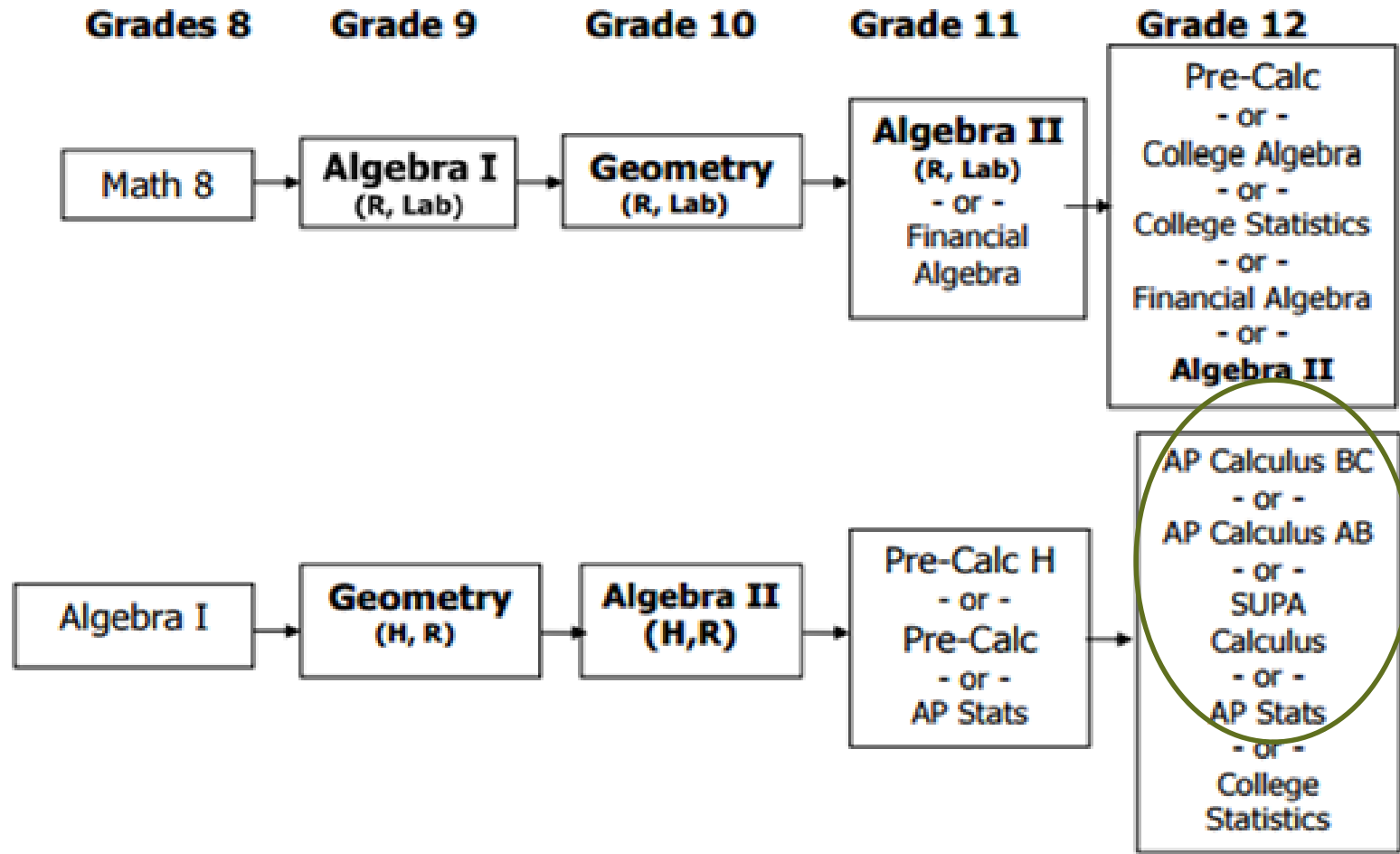



## SCIENCE

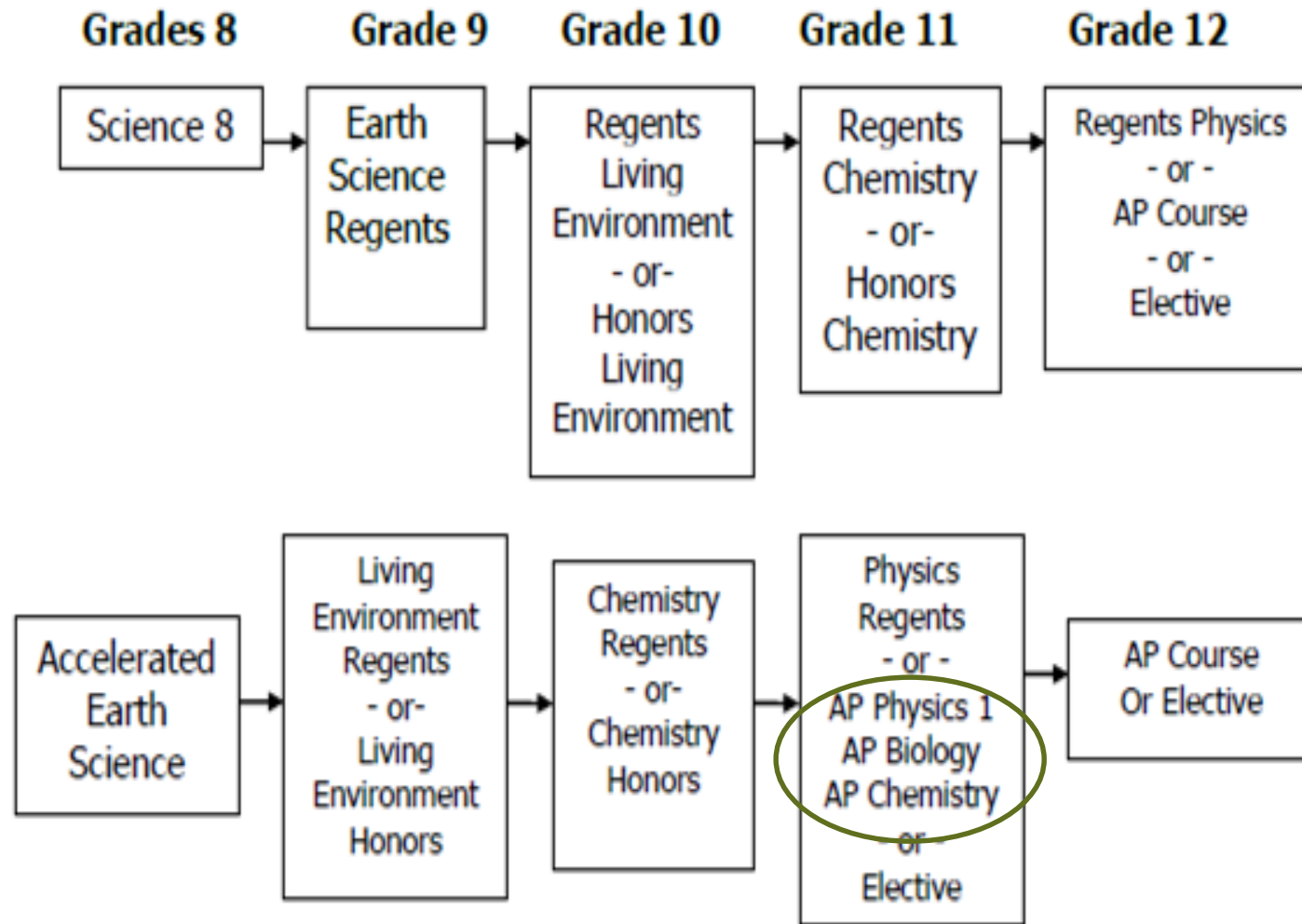

# End of Year Assessments

Students taking Earth Science and Algebra will take the New York State Regents Exam in those subjects.



Students will take the World Languages FLACS Exam.

These scores will be reflected on students' high school transcripts.



Students will also take Final Exams in major subject areas.

# Traditional Schedule

	Term Q1 (09/09/15- 11/13/15)	Term Q2 (11/16/15- 02/01/16)	Term Q3 (02/02/16- 04/07/16)	Term Q4 (04/08/16- 06/24/16)
<b>Zero</b>	EMPTY	EMPTY	EMPTY	EMPTY
<b>MAP</b>	998-67 MIDDLE SCHOOL ADVISORY PROGRAM Curran, D. Rm: C27	998-67 MIDDLE SCHOOL ADVISORY PROGRAM Curran, D. Rm: C27	998-67 MIDDLE SCHOOL ADVISORY PROGRAM Curran, D. Rm: C27	998-67 MIDDLE SCHOOL ADVISORY PROGRAM Curran, D. Rm: C27
<b>1</b>	812-3 ENGLISH 8 Ninivaggi, P. Rm: D6 Team: 8A	812-3 ENGLISH 8 Ninivaggi, P. Rm: D6 Team: 8A	812-3 ENGLISH 8 Ninivaggi, P. Rm: D6 Team: 8A	812-3 ENGLISH 8 Ninivaggi, P. Rm: D6 Team: 8A
<b>2</b>	822-4 MATH 8 Milone/Arnow Rm: C24	822-4 MATH 8 Milone/Arnow Rm: C24	822-4 MATH 8 Milone/Arnow Rm: C24	822-4 MATH 8 Milone/Arnow Rm: C24
<b>3</b>	805-3 (1, 3, 5) PHYS ED 8 Salerno, K. Rm: GYM <hr/> 843-1 (2, 4, 6) HEALTH 8 Ferreira, K. Rm: D32	805-3 (1, 3, 5) PHYS ED 8 Salerno, K. Rm: GYM <hr/> 843-1 (2, 4, 6) HEALTH 8 Ferreira, K. Rm: D32	805-3 (1, 3, 5) PHYS ED 8 Salerno, K. Rm: GYM <hr/> 843-1 (2, 4, 6) HEALTH 8 Ferreira, K. Rm: D32	805-3 (1, 3, 5) PHYS ED 8 Salerno, K. Rm: GYM <hr/> 843-1 (2, 4, 6) HEALTH 8 Ferreira, K. Rm: D32
<b>4</b>	806-1 LUNCH 8 Rm: CAFE	806-1 LUNCH 8 Rm: CAFE	806-1 LUNCH 8 Rm: CAFE	806-1 LUNCH 8 Rm: CAFE
<b>5</b>	850-7 SPANISH 1R Schaefer, M. Rm: D26	850-7 SPANISH 1R Schaefer, M. Rm: D26	850-7 SPANISH 1R Schaefer, M. Rm: D26	850-7 SPANISH 1R Schaefer, M. Rm: D26
<b>6</b>	840-4 SCIENCE 8 Gonzalez, Y. Rm: C3	840-4 SCIENCE 8 Gonzalez, Y. Rm: C3	840-4 SCIENCE 8 Gonzalez, Y. Rm: C3	840-4 SCIENCE 8 Gonzalez, Y. Rm: C3
<b>7</b>	830-6 SOC STUDIES 8 Maiello, J. Rm: C30	830-6 SOC STUDIES 8 Maiello, J. Rm: C30	830-6 SOC STUDIES 8 Maiello, J. Rm: C30	830-6 SOC STUDIES 8 Maiello, J. Rm: C30
<b>8</b>	802-1 (1, 3, 5) ART 8 Psillos, S. Rm: C5 <hr/> 803-1 (2, 4, 6) TECHNOLOGY 8 Olitsky, D. Rm: TECA <b>Start: 09/10/2015</b>	802-1 (1, 3, 5) ART 8 Psillos, S. Rm: C5 <hr/> 803-1 (2, 4, 6) TECHNOLOGY 8 Olitsky, D. Rm: TECA	802-1 (1, 3, 5) ART 8 Psillos, S. Rm: C5 <hr/> 803-1 (2, 4, 6) TECHNOLOGY 8 Olitsky, D. Rm: TECA	802-1 (1, 3, 5) ART 8 Psillos, S. Rm: C5 <hr/> 803-1 (2, 4, 6) TECHNOLOGY 8 Olitsky, D. Rm: TECA



# Algebra 1 and Earth Science

	Term Q1 (09/09/15- 11/13/15)	Term Q2 (11/16/15- 02/01/16)	Term Q3 (02/02/16- 04/07/16)	Term Q4 (04/08/16- 06/24/16)
<b>Zero</b>	EMPTY	EMPTY	EMPTY	EMPTY
<b>MAP</b>	998-67 MIDDLE SCHOOL ADVISORY PROGRAM Curran, D. Rm: C27	998-67 MIDDLE SCHOOL ADVISORY PROGRAM Curran, D. Rm: C27	998-67 MIDDLE SCHOOL ADVISORY PROGRAM Curran, D. Rm: C27	998-67 MIDDLE SCHOOL ADVISORY PROGRAM Curran, D. Rm: C27
<b>1</b>	301-2 ALGEBRA I Milone, E. Rm: C24	301-2 ALGEBRA I Milone, E. Rm: C24	301-2 ALGEBRA I Milone, E. Rm: C24	301-2 ALGEBRA I Milone, E. Rm: C24
<b>2</b>	850-6 SPANISH 1R Schaefer, M. Rm: D26	850-6 SPANISH 1R Schaefer, M. Rm: D26	850-6 SPANISH 1R Schaefer, M. Rm: D26	850-6 SPANISH 1R Schaefer, M. Rm: D26
<b>3</b>	830-7 SOC STUDIES 8 Antonietto/Arnow Rm: C32	830-7 SOC STUDIES 8 Antonietto/Arnow Rm: C32	830-7 SOC STUDIES 8 Antonietto/Arnow Rm: C32	830-7 SOC STUDIES 8 Antonietto/Arnow Rm: C32
<b>4</b>	806-1 LUNCH 8 Rm: CAFE	806-1 LUNCH 8 Rm: CAFE	806-1 LUNCH 8 Rm: CAFE	806-1 LUNCH 8 Rm: CAFE
<b>5</b>	802-1-3 (1, 3, 5) ART 8 ES Goscinski, M. Rm: C6	802-1-3 (1, 3, 5) ART 8 ES Goscinski, M. Rm: C6	941-3 (1, 3, 5) TECHNOLOGY 8 ES Courtesis, L. Rm: TECC	941-3 (1, 3, 5) TECHNOLOGY 8 ES Courtesis, L. Rm: TECC
	844-3 (2, 4, 6) HEALTH 8 ES Miller, J. Rm: C23	844-3 (2, 4, 6) HEALTH 8 ES Miller, J. Rm: C23	844-3 (2, 4, 6) HEALTH 8 ES Miller, J. Rm: C23	844-3 (2, 4, 6) HEALTH 8 ES Miller, J. Rm: C23
<b>6</b>	812-7 ENGLISH 8 Ninivaggi, P. Rm: D6 Team: 8A	812-7 ENGLISH 8 Ninivaggi, P. Rm: D6 Team: 8A	812-7 ENGLISH 8 Ninivaggi, P. Rm: D6 Team: 8A	812-7 ENGLISH 8 Ninivaggi, P. Rm: D6 Team: 8A
<b>7</b>	807-4 (1, 3, 5) PHYS ED 8 ES Salerno, K. Rm: GYM	807-4 (1, 3, 5) PHYS ED 8 ES Salerno, K. Rm: GYM	807-4 (1, 3, 5) PHYS ED 8 ES Salerno, K. Rm: GYM	807-4 (1, 3, 5) PHYS ED 8 ES Salerno, K. Rm: GYM
	403-2-2 (2, 4, 6) EARTH SCI-R-LAB Menchel, J. Rm: C1 Team: 8A	403-2-2 (2, 4, 6) EARTH SCI-R-LAB Menchel, J. Rm: C1 Team: 8A	403-2-2 (2, 4, 6) EARTH SCI-R-LAB Menchel, J. Rm: C1 Team: 8A	403-2-2 (2, 4, 6) EARTH SCI-R-LAB Menchel, J. Rm: C1 Team: 8A
<b>8</b>	403-1-2 EARTH SCI-R+LAB Menchel, J. Rm: C1 Team: 8A	403-1-2 EARTH SCI-R+LAB Menchel, J. Rm: C1 Team: 8A	403-1-2 EARTH SCI-R+LAB Menchel, J. Rm: C1 Team: 8A	403-1-2 EARTH SCI-R+LAB Menchel, J. Rm: C1 Team: 8A
<b>9</b>	766-1 STRING ORCH 6/7/8 Lucas, E. Rm: ORCH	766-1 STRING ORCH 6/7/8 Lucas, E. Rm: ORCH	766-1 STRING ORCH 6/7/8 Lucas, E. Rm: ORCH	766-1 STRING ORCH 6/7/8 Lucas, E. Rm: ORCH

# Additional Opportunities Available During Zero Period

## Zero Period

- Clubs
- ELA AIS
- Math AIS

## Ninth Period

- Remedial (Monday, Tuesday, and Thursday)

## Successful 2017/2018 School Year

- Construct a program of courses that is appropriate
- Acceleration in all courses is not always the best option
- Take into account course recommendations prior to Self-Selecting
- Continually monitor the information on the Portal
- Teacher Contact (Phone, E-mail & Team Meetings)
- Join and attend PTA Meetings
- Open door policy
- Encourage the use of remedial whenever possible



# Questions and/or Concerns

## Howard B. Mattlin Middle School

---

Incoming Grade 8  
Parent Transition Meeting  
January 10, 2017

*Joseph Coladonato, Ed.D., Principal*

*Regina Talento, Assistant Principal (Grades 5 & 7)*

*Andrea Luzzi, Guidance Counselor*